



Technical Data

SCO4P Enclosed Changeover Switches

IP65



- 4 Pole Range available from 20A to 100A
- IP65 Protection Rating (enclosure)
- EN 60947-3 Compliant
- 2 Sizes of Enclosure
- Multiple Gland Knockouts
- 3 Position Handle with Centre OFF
- Flame Retardant
- External Mounting Points
- Additional Earth Connection

ORDERING INFORMATION

Part Number	Current I _e (AC21)	Rated Operating Voltage	Poles
SCO4P20	20A	230-440V	4
SCO4P32	32A	230-440V	4
SCO4P40	40A	230-440V	4
SCO4P63	63A	230-440V	4
SCO4P80	80A	230-440V	4
SCO4P100	100A	230-440V	4

DIMENSIONS (mm)

Part Number	Height	Width	Depth	Depth inc. Handle	Gland Knockouts
SCO4P20	176	116	101	136	M20/25
SCO4P32	176	116	101	136	M20/25
SCO4P40	176	116	101	136	M20/25
SCO4P63	240	160	122	159	M25/32
SCO4P80	240	160	122	159	M25/32
SCO4P100	240	160	122	159	M25/32

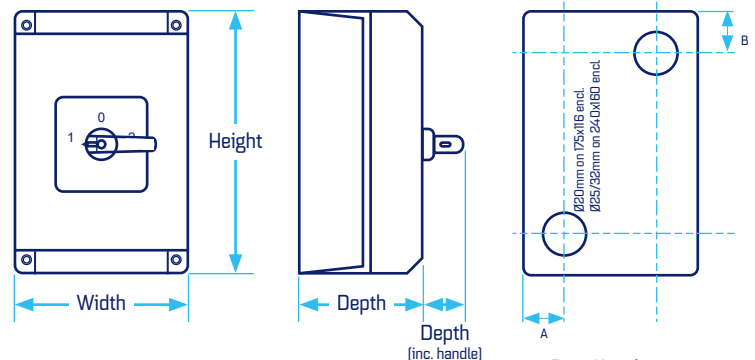
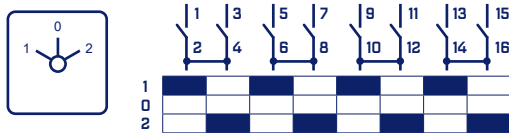

Rear Knockouts
 A: 27.5mm on 175x116mm enclosure
 42mm on 240x160mm enclosure
 B: 25mm on 175x116mm enclosure
 42.0mm on 240x160mm enclosure

GENERAL INFORMATION

Enclosure Material	Polycarbonate
Lid Screw Material	Stainless Steel
Ingress Protection	IP65 Enclosure / IP20 Body
Interlocked Handle	n/a
Approvals	UKCA, CE, SEMKO
Compliance	IEC EN 60947-3, RoHS

TECHNICAL SPECIFICATION

Part Number	SCO4P20	SCO4P32	SCO4P40	SCO4P63	SCO4P80	SCO4P100
Poles	4	4	4	4	4	4
Rated Operational Current I_e [AC21] [A]	20	32	40	63	80	100
Rated Power of 3Ph Motor at 415V [AC23A] [kW]	7	12	15	22	30	37
Rated Voltage [V]	415	415	415	415	415	415
Frequency [Hz]	50/60	50/60	50/60	50/60	50/60	50/60
Rated Insulation Voltage U_i [V]	690	690	690	690	690	690
Max. Cable Size (Solid/Stranded) [mm²]	10	10	10	35	35	35
Rated Cond. Short Circuit Current [A]	20 I _e	20 I _e	20 I _e	20 I _e	20 I _e	20 I _e
Short Time Withstand Current 415V 1 sec. [A]	12 I _e	12 I _e	12 I _e	12 I _e	12 I _e	12 I _e
Rated Make/Break Capacity [A]	8 I _e	8 I _e	8 I _e	8 I _e	8 I _e	8 I _e
Protection Degree	IP65	IP65	IP65	IP65	IP65	IP65
Tightening Torque [Nm]	2	2	2	3	3	3
Mechanical Life [10³]	10	10	10	10	10	10
Weight [kg]	0.75	0.75	0.75	1.85	1.85	1.85

For more information, email info@stag-electrical.com.au