



Technical Data

SST Mechanical Staircase Time Switch

IP20



- Mechanical Staircase Time Switch
- Countdown from 30sec. - 20min.
- Electronic Overload Protection
- DIN Rail Mounting (TS 35)
- External Push Switch Control
- Toggle Switch for Permanent Light

ORDERING INFORMATION

| Part Number | Features |
|-------------|----------------------|
| SST-5-1C | Timer with Countdown |

DIMENSIONS (mm)

| Part Number | Height | Width [w] | Depth | x |
|-------------|--------|-----------|-------|------|
| SST-5-1C | 81.5 | 18.0 | 66.0 | 45.0 |

GENERAL INFORMATION

| | |
|--------------------|----------------------------------|
| Enclosure Material | Self-Extinguishing Thermoplastic |
| Protection Class | Class II According to EN 60730-1 |
| Ingress Protection | IP20 |
| Approvals | UKCA, CE, RoHS |
| Mounting Type | DIN Rail (TS 35) |

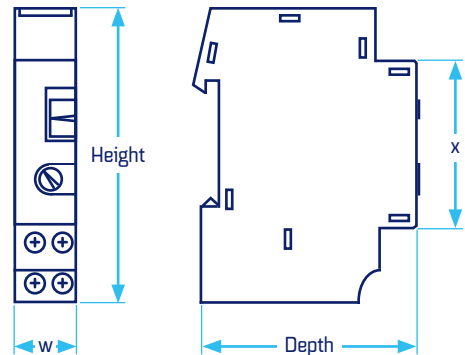

TECHNICAL SPECIFICATION

| Part Number | SST-5-1C |
|-------------------------------------|------------------------------------|
| Supply Voltage | 220V AC, 50/60Hz |
| Switching Capacity (Resistive Load) | 16A / 250V - at $\cos \phi=1$ |
| Switching Capacity (Inductive Load) | 10A / 250V - at $\cos \phi=0.6$ |
| 1/2-Way Conductors | Automatic |
| Countdown Range | 30sec. - 20mins. |
| | 0 - 20mins. (± 150 secs.) |
| | 0 - 30secs. (± 3 secs.) |
| Power Consumption | 4VA |
| Switching Output | Potential Free & Phase Independent |
| Glow Lamp Load | 150mA max. |
| Ambient Operating Temperature | -10°C to + 50°C |

| Max. Recommended Load (10,000 Ops) | SST-5-1C |
|---------------------------------------|----------|
| LED Lamp <2W | 20W |
| LED Lamp 2-8W | 55W |
| LED Lamp >8W | 70W |
| Filament/Halogen Lamp 230V | 2300W |
| Energy Saving Lamp | 90W |
| Flourescent Lamp (Electronic Ballast) | 230W |

WIRING DIAGRAM

With Neon Lamp

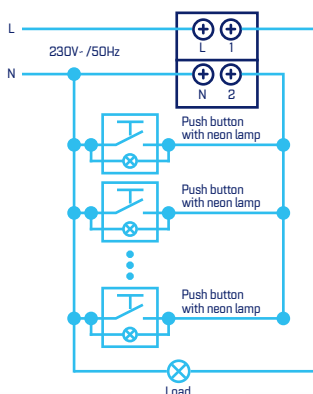

Without Neon Lamp

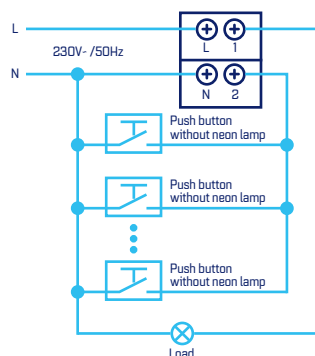

For more information, email info@stag-electrical.com.au